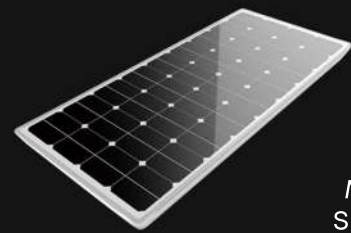




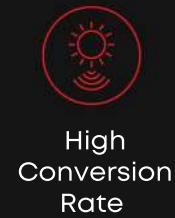
ISES ALL IN ONE
SOLAR STREET LIGHT

> Features of SES Series

- SES solar LED street light features all in one design function, low profile design, with PIR/microwave motion sensor and smart controller all built in.
- Integral monocrystalline silicon solar panel, suitable for remote region, non electricity supply zone.
- Deep cycle battery, charge and discharge over 2000 times.
- Maximum Autonomy: Operate 1~2 rainy days under intelligent model.
- Heavy duty die cast aluminum housing. UV Stabilized polyester powder paint finish rated for 1000 hour salt spray.



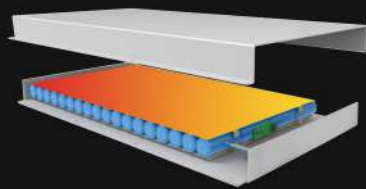
Integral Monocrystalline Silicon Solar Panel



High Conversion Rate



25 Years Lifespan



High quality A-Class LiFePO4 battery. Lifespan cycle more than 2000 times. Intelligent charge and discharge management system.

UP TO
180
lm/W

CRI
70/80/90

• 3000K
• 4000K
• 5000K
• 5700K
• 6500K

L90B10
>100000hrs
@ 25°C

IP65

ROTATABLE LED MODULE

DIM

IoT-4G Zigbee

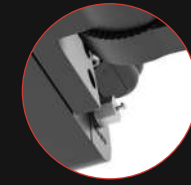
Smart Sensor



±45° rotatable LED module



Sensor mounting position



On/Off power switch



- Unique anti-theft technology on battery door. Easy battery replacement design.
- Rotatable LED module. Single LED up to 180lm/W. Worry-free installation, best solar panel angle adapt to the sun.
- 2.4g wireless remote programmable remote control available. Modify the controller on mode and read the system running status
- Replace the traditional 30-120 watts. From 10 to 60 watts, meeting all road application conditions.
- Customizable road optical designs. Adapt to various road conditions but no waste of light.
- PIR/microwave motion sensor and smart controller all built in, energy saving. MPPT charging, improve the utilization rate of solar energy charging by more than 20%.

> Photometrics Design

Lumen efficiency >180lm/W achieve higher illumination



High Efficiency Long Lifespan Less Calorific Value Low Light Decay

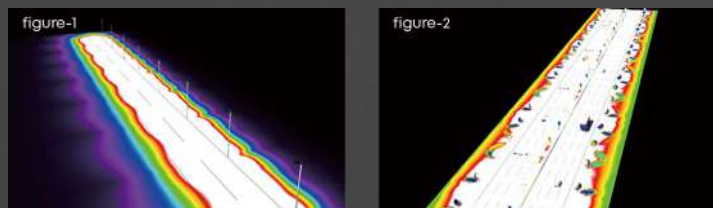


High quality 5050 LED chip creates a first-class light source. By choosing it, single lumen efficacy up to 180lm/W, with the aluminum lamp base and sealed lens, with its excellent heat dissipation, it is as if the LED chip has been placed in a sealed unit. Thus it maintains high brightness levels with very little fading. The sealed lenses are made of strong UV-protected PC and are aging and shock-resistant; The well-optimized light distribution makes for a more uniform and wider lighting area.

Distribution

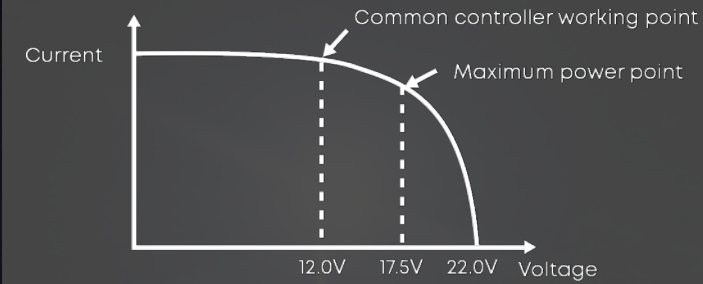


Figure-1: Example of rural branch road
Figure-2: Example of mian road or avenue



Planning and analysis of street lights can be done by using lighting simulation & design software, which allows the lighting effect a more intuitive display. It uses rendering, the process of generating an image from a model, by means of computer programs resulting in different tools for measuring the simulated light levels.

Advantages of controller

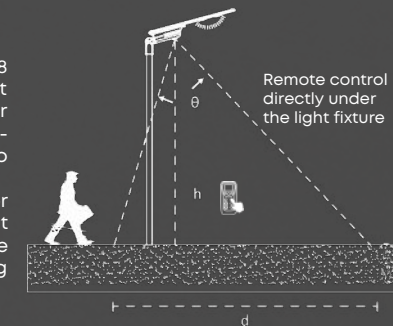


(take 12V battery system as an example)

- 1) Moving Track MPPT maximum power tracking technology is adopted to improve the tracking efficiency and speed by more than 20%;
- 2) UltraGreen power control technology with extremely low static power consumption and sleep current;
- 3) 10 time-periods programmable load power/time control;
- 4) Multiple intelligent power modes can be selected, and the load power can be automatically adjusted according to the battery power;
- 5) Multiple protection functions such as battery /PV reverse connection protection, LED short circuit/open circuit/power limit protection;
- 6) Aluminum metal housing, IP67 waterproof rating, can be used in a variety of harsh environments
- 7) Extensible IoT remote communication monitoring function;

Detection distance

Remote control distance 5-8 meters, installation height and environment and other factors will affect the controller sensitivity, please refer to the actual field.
Note: Please do not place 2 or more lights within 12 meters at the same time while using the remote controller, receiving or sending may fail.



Inductive Type (alternative)	θ -Angle (X-axis rotation: 360°)	h (Height of lamp rod)	d (Inductive width)
IR (Infrared)	60°	6-8m	6-10m
WVB (Microwave)	65°	6-10m	7-10m

*Remote control is optional

> Application Reference

- Road lighting
- Area lighting
- Perimeter lighting



> Application of Typical Networking of Smart Street Light(optional)

Strategy Control

By installing the node of the street light controller on the ambient light sensor, electric energy metering unit to collect to the street light power (voltage, current, power), and the ambient light conditions, according to the administrator deployment strategy to mobilize installed on the street light controller of the automatic control system to control the street light switch, adjust brightness, color temperature adjustment, etc.;

Gateway Control

The Lora Light wireless system with strong anti-interference ability is adopted in the wireless transmission unit of the street light controller to realize the communication between nodes and gateways. The data of various sensors on the node street lamp controller is sent back to the gateway, and the control command of the gateway is also sent to the node street light controller.

Cloud Platform

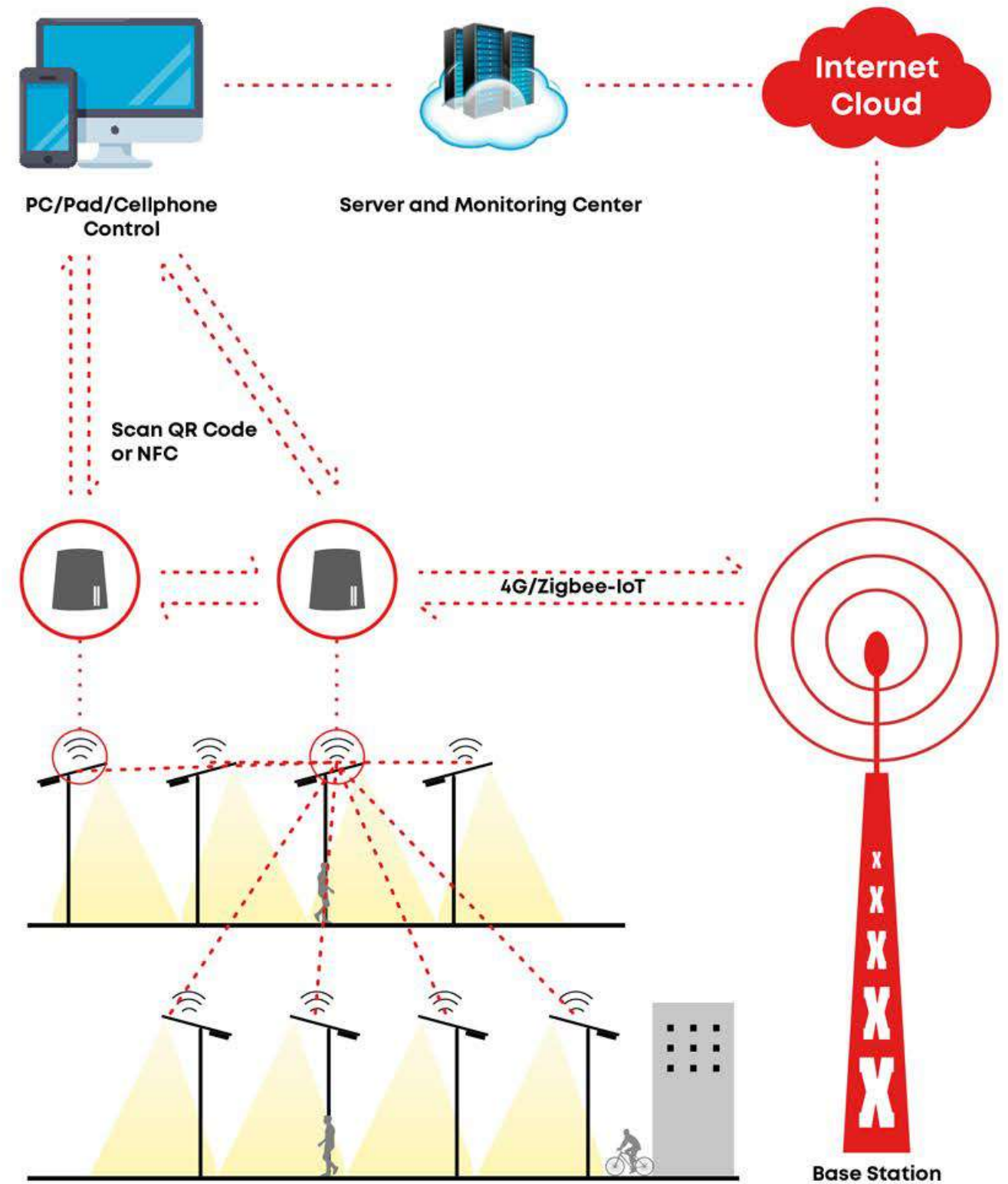
The gateway controller transmits the street light control information of all nodes under the gateway to the cloud platform through 4G/Zigbee-IoT (optional) wireless mode, and at the same time sends the instructions of the cloud platform to the street light controller of each node.

Controller 4G/Zigbee-IoT Inside



- Built-in IoT module (4G/Zigbee-IoT)
- Adopt Moving Track MPPT maximum power tracking technology, with higher tracking efficiency and faster speed;
- Lead-acid battery and lithium battery are universal. Operating parameters can be set by remote controller;
- Ultra green power control technology with extremely low static power consumption and dormant current;
- Lead acid battery multi-stage temperature compensated constant voltage charging;
- 10 Programmable load power/time control setting;
- Battery charging and discharging high and low temperature protection function, working temperature can be set;
- A variety of intelligent modes can be selected, automatically adjust the load power according to the battery power;
- High precision digital booster constant-current control algorithm, high efficiency and high constant-current precision;
- 2.4G wireless communication, can set read parameters, read status, etc;
- Battery/PV reverse connection protection, LED short circuit/open circuit/limited power protection and other multiple protection functions.

APPLICATION OF TYPICAL IOT NETWORKING



Parameter Table

Autonomy 5-7 Hours without dimming profile without run time extension								
Electrical Data								
Model	10WSES	15WSES	27WSES	40WSES	50WSES	67WSES	95WSES	
Power (Std. Dev. ±3%)	10W	15W	27W	40W	50W	67W	95W	
Input voltage	3.2VDC		12VDC				24VDC	
Control Option	Photocell sensor, timing, dimming, intelligent power saving, microwave sensor or PIR sensor.							
Photometric Data								
LED Manufacturer	REFOND / SMALITE							
LED model and quantity	5050 12 Pcs	5050 18 Pcs	5050 32 Pcs	5050 32 Pcs	5050 44 Pcs	5050 60 Pcs	5050 96 Pcs	
Lens Material	Polycarbonate (PC)							
Efficacy (lm/w, Std. Dev. ±3%)	180	180	180	180	180	180	180	
Luminous flux (lm, Std. Dev. ±3%)	1800	2700	4800	7200	9000	12060	17100	
ULOR	= 0%, @ Luminaire inclination 0°							
CCT	3000K, 4000K, 5000K, 5700K, 6500K							
CRI	Ra>70							
Beam Angle	T2/T3/T5							
Mechanical Data								
IP Rating	IP65, according to standard EN 60529							
Housing Material	Heavy-duty die-cast aluminum							
Surface Treatment	Anti-UV thermosetting polyester							
Housing Color	Black, Custom request							
Mounting Bracket Options	Universal/Wall mount/Round pole/Square pole							
Solar Panel and Battery Data (25°C)								
Photovoltaic panel	single side monocrystalline solar panel							
Solar Panel-MPPT (Std. Dev. ±3%)	18V/10W	18V/15W	18V/25W	16V/40W	18V/50W	18V/60W	36V/80W	
Lithium Ferro Phosphate Battery	57.6WH	76.8WH	153.6WH	230.4WH	307.2WH	384.0WH	614.4WH	
	3.2V18AH	3.2V24AH	12.8V12AH	12.8V18AH	12.8V24AH	12.8V30AH	25.6V24AH	
Charing Time (MPPT) (hrs)	6.0hrs	5.4hrs	6.4hrs	6.0hrs	6.4hrs	6.7hrs	8.0hrs	
Battery lifespan	>2000 times cycle							
Autonomy without dimming profile without run time extension (hrs)	5.2hrs	4.6hrs	5.1hrs	5.2hrs	5.6hrs	5.2hrs	5.8hrs	
Autonomy Mode	Motion: 0-2 hrs-100%; 2-5 hrs-60%; 5-9 hrs-30%; 9-12 hrs-100%; Without Motion: 0-2 hrs-30%; 2-5 hrs-20%; 5-9 hrs-10%; 9-12 hrs-50%;							
Ambient Temperature	-10°C to 50°C (14°F to 122°F)							
Storage Temperature	-20°C to 45°C (-4°F to 113°F)							
Charge Controller	MPPT intelligent controller							
Maximum Autonomy	Operate 1~2 rainy days under intelligent model							
Package Info								
Product Size	465*366*133mm	465*366*133mm	560*366*133mm	750*366*133mm	910*366*133mm	1080*366*133mm	1345*366*133mm	
Net Weight	8.5kg	8.7kg	10kg	11.5kg	13.5kg	14.5kg	19kg	
Carton Size	580*210*440mm	580*210*440mm	675*210*440mm	865*210*440mm	1025*210*440mm	1195*210*440mm	1460*210*440mm	
Gross Weight	12.5kg	12.7kg	13kg	14.5kg	16.5kg	17.5kg	22kg	
Others								
Lifespan	L90B10 - 100000 hrs, @Tq 25°C							
Warranty	Standard 3 Year Warranty							
Certification	CB, CE, RoHS, For other certificates please request							
Recommend Installation Height	3-6m	4-7m	5-8m	5-8m	6-9m	6-10m	8-12m	
Application Field	Urban and rural street							
EPA Ratings	Top View-0.211m ² Front View-0.049m ² Side View-0.052m ²	Top View-0.211m ² Front View-0.049m ² Side View-0.052m ²	Top View-0.246m ² Front View-0.049m ² Side View-0.055m ²	Top View-0.329m ² Front View-0.049m ² Side View-0.059m ²	Top View-0.400m ² Front View-0.049m ² Side View-0.063m ²	Top View-0.474m ² Front View-0.049m ² Side View-0.070m ²	Top View-0.591m ² Front View-0.049m ² Side View-0.084m ²	

Autonomy 12-16 Hours without dimming profile without run time extension							
Electrical Data							
Model	10WSES	15WSES	27WSES	40WSES	50WSES	67WSES	95WSES
Power (Std. Dev. ±3%)	10W	15W	27W	40W	50W	67W	95W
Input voltage	12VDC						24VDC
Control Option	Photocell sensor, timing, dimming, intelligent power saving, microwave sensor or PIR sensor.						
Photometric Data							
LED Manufacturer	REFOND / SMALITE						
LED model and quantity	5050 12 Pcs	5050 18 Pcs	5050 32 Pcs	5050 32 Pcs	5050 44 Pcs	5050 60 Pcs	5050 96 Pcs
Lens Material	Polycarbonate (PC)						
Efficacy (lm/w, Std. Dev. ±3%)	180	180	180	180	180	180	180
Luminous flux (lm, Std. Dev. ±3%)	1800	2700	4800	7200	9000	12060	17100
ULOR	= 0%, @ Luminaire inclination 0°						
CCT	3000K, 4000K, 5000K, 5700K, 6500K						
CRI	Ra>70						
Beam Angle	T2/T3/T5						
Mechanical Data							
IP Rating	IP65, according to standard EN 60529						
Housing Material	Heavy-duty die-cast aluminum						
Surface Treatment	Anti-UV thermosetting polyester						
Housing Color	Black, Custom request						
Mounting Bracket Options	Universal/Wall mount/Round pole/Square pole					Universal	Universal
Solar Panel and Battery Data (25°C)							
Photovoltaic panel	single side monocrystalline solar panel						
Solar Panel -MPPT (Std. Dev. ±3%)	18V/20W	18V/30W	18V/50W	18V/80W	18V/90W	18V/100W	36V/160W
Lithium Ferro Phosphate Battery	153.6WH	230.4WH	384.0WH	537.6WH	614.4WH	844.8WH	1228.8WH
	12.8V12AH	12.8V18AH	12.8V30AH	12.8V42AH	12.8V48AH	12.8V66AH	25.6V48AH
Charing Time (MPPT) (hrs)	8.0hrs	8.0hrs	8.0hrs	7.0hrs	7.1hrs	8.8hrs	8.0hrs
Battery lifespan	>2000 times cycle						
Autonomy without dimming profile without run time extension (hrs)	14.0hrs	14.0hrs	12.9hrs	12.2hrs	11.2hrs	11.4hrs	11.6hrs
Autonomy Mode	Motion: 0-2 hrs-100%; 2-5 hrs-60%; 5-9 hrs-30%; 9-12 hrs-100%; Without Motion: 0-2 hrs-30%; 2-5 hrs-20%; 5-9 hrs-10%; 9-12 hrs-50%;						
Ambient Temperature	-10°C to 50°C (14°F to 122°F)						
Storage Temperature	-20°C to 45°C (-4°F to 113°F)						
Charge Controller	MPPT intelligent controller						
Maximum Autonomy	Operate 3~5 rainy days under intelligent model						
Package Info							
Product Size	465*366*133mm	580*366*133mm	910*366*133mm	1345*366*133mm	1530*366*133mm	1670*366*133mm	1812*522*225mm
Net Weight	9kg	10kg	13.5kg	17kg	19kg	32kg	38kg
Carton Size	580*210*440mm	695*210*440mm	1025*210*440mm	1460*210*440mm	1645*210*440mm	1785*210*440mm	2089*600*210mm
Gross Weight	11.5kg	13kg	16.5kg	20kg	22kg	35kg	40kg
Others							
Lifespan	L90B10 - 100000 hrs, @Tq 25°C						
Warranty	Standard 3 Year Warranty						
Certification	CB, CE, RoHS, For other certificates please request						
Recommend Installation Height	3-6m	4-7m	5-8m	5-8m	6-9m	6-10m	8-12m
Application Field	Urban and rural street						
EPA Ratings	Top View-0.211m ² Front View-0.049m ² Side View-0.052m ²	Top View-0.246m ² Front View-0.049m ² Side View-0.055m ²	Top View-0.400m ² Front View-0.049m ² Side View-0.063m ²	Top View-0.591m ² Front View-0.049m ² Side View-0.084m ²	Top View-0.674m ² Front View-0.049m ² Side View-0.089m ²	Top View-0.738m ² Front View-0.049m ² Side View-0.094m ²	Top View-1.12m ² Front View-0.07m ² Side View-0.16m ²

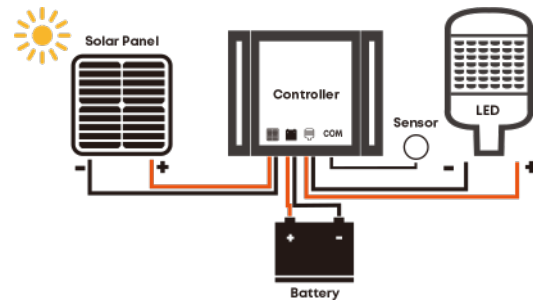
SES Series Specification Sheet

*Due to the constant improvements in product development, individual parameters might change. Please refer to our sales or R&D team for most up-to-date content as specifications are subject to change without notice.

Tel: (+34) 93 3174 008
E-mail: info@carandini.com
Web: carandini.com
Address: C Y G Carandini, S.A.U. Anselm Clavé, 22408186 Lliçà d'Amunt Barcelona, Spain



Working Way



The solar panel receives solar radiation energy and converts it into electricity, which is stored in the battery by the photovoltaic controller. At night, when the illumination gradually decreases to about 10LUX and the solar panel voltage is 5V, the charge and discharge controller detects this voltage value, and controls the battery to discharge for the LEDs to complete the process of daytime charging and evening discharge.

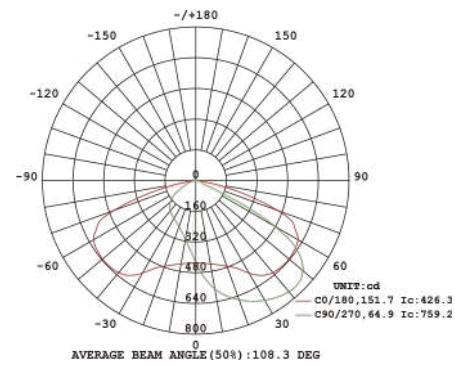
Ordering Information

WATTS	VOLTAGE	LED CHIPS	TYPE OF SENSOR	CCT&CRI	DISTRIBUTION	MOUNT	COLOR
10WSES	NV1=3.2V DC	REFOND / SMALITE	00=Without Sensor	3070=3000K 70CRI	T2=TYPE II	Type A	BK=Black
15WSES	NV2=12.8V DC		SN=Motion Sensor	4070=4000K 70CRI	T3=TYPE III	Type B	
27WSES	NV3=25.6V DC		PIR=PIR Sensor	5070=5000K 70CRI	T5=TYPE V	Type C	
40WSES				5770=5700K 70CRI		Type D	
50WSES							
67WSES							
95WSES							

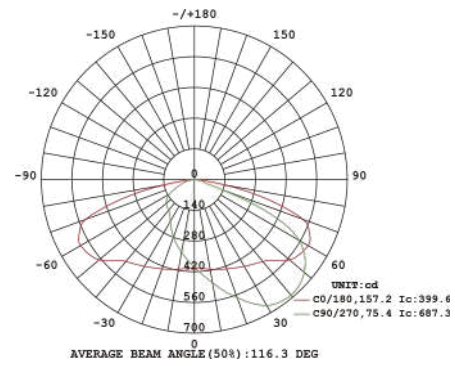
Accessories (Order separately)
 IOT Management
 AC & DC complementary

Photometry

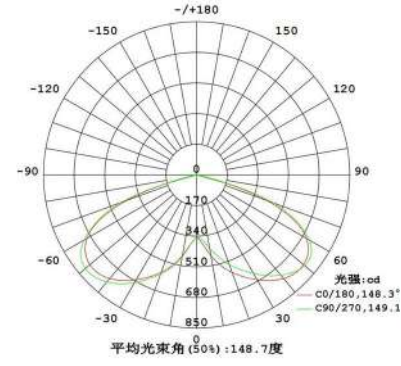
Type II



Type III

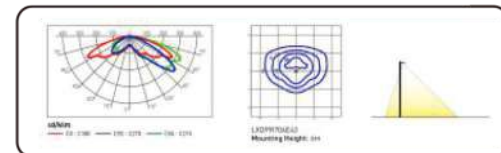
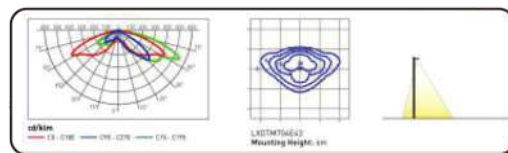


Type V

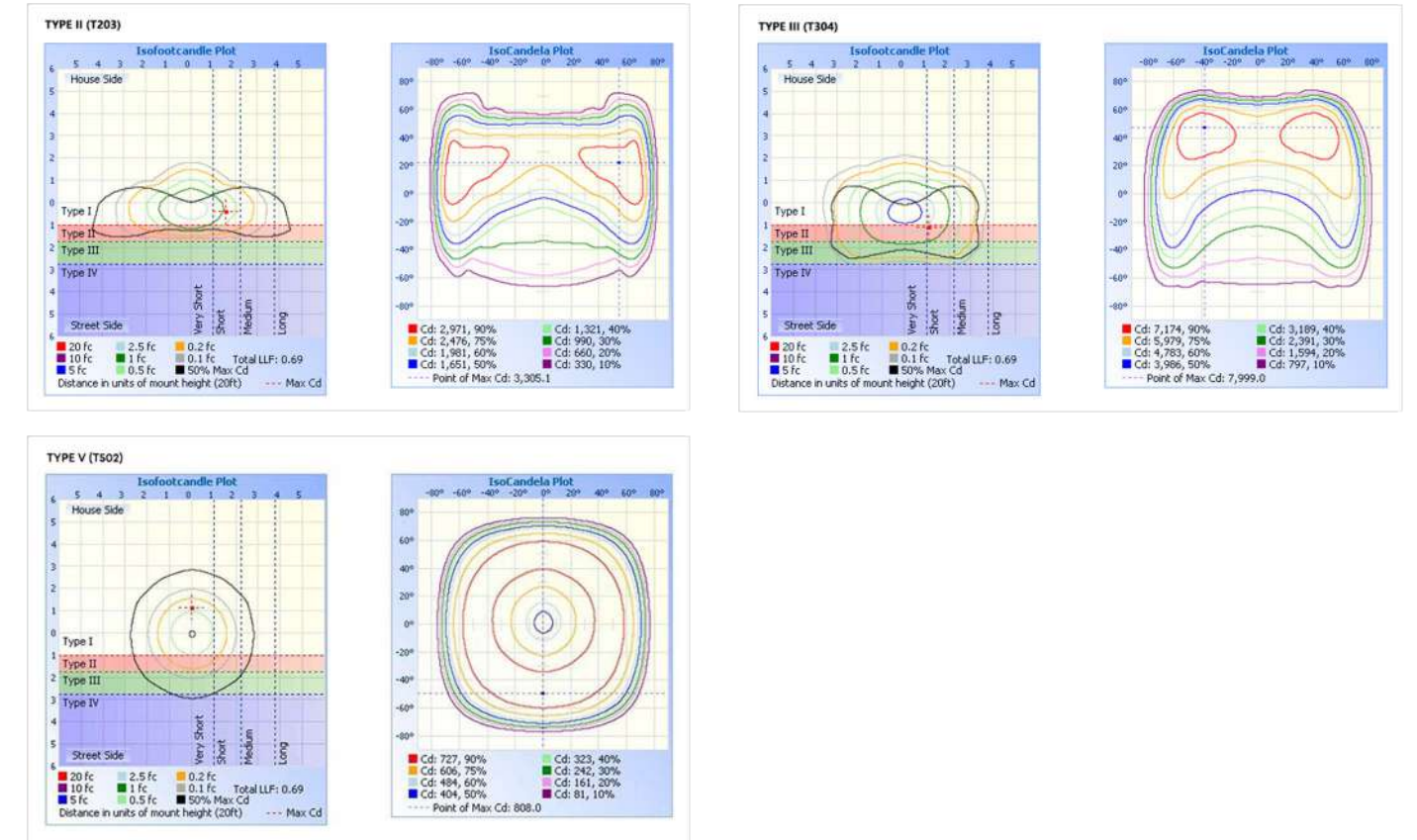


Type 2 for street lighting, cycle paths and footpaths

Type 3 for street light and car parks



Illuminance Diagram



Accessories

Mounting Options



Type A
Universal Bracket



Type B
Wall Mount



Type C
Round Pole



Type D
Square Pole

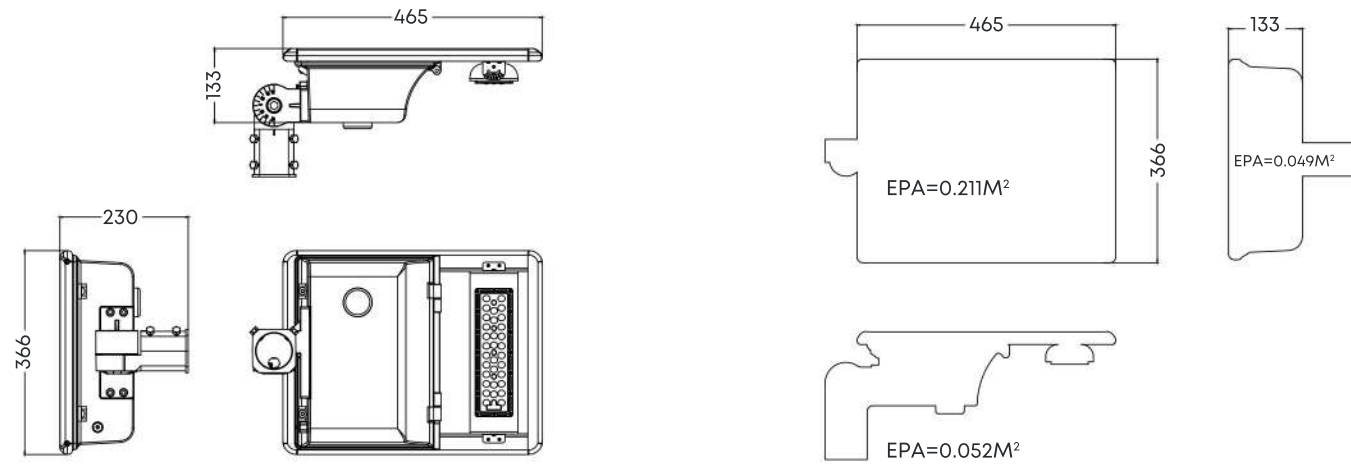


PIR/microwave
Motion Sensor

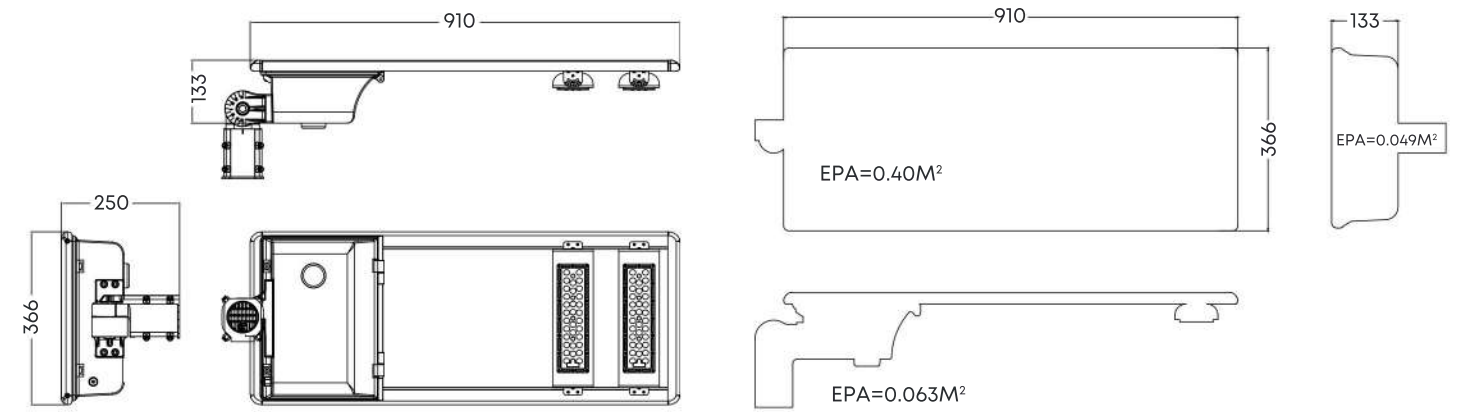
*As the products are upgraded, the accessories may differ from those described in the pictures. Please consult with our sales team for updated details and order separately.

Dimensions (Length unit: mm) *Autonomy 5-7 Hours without dimming profile without run time extension

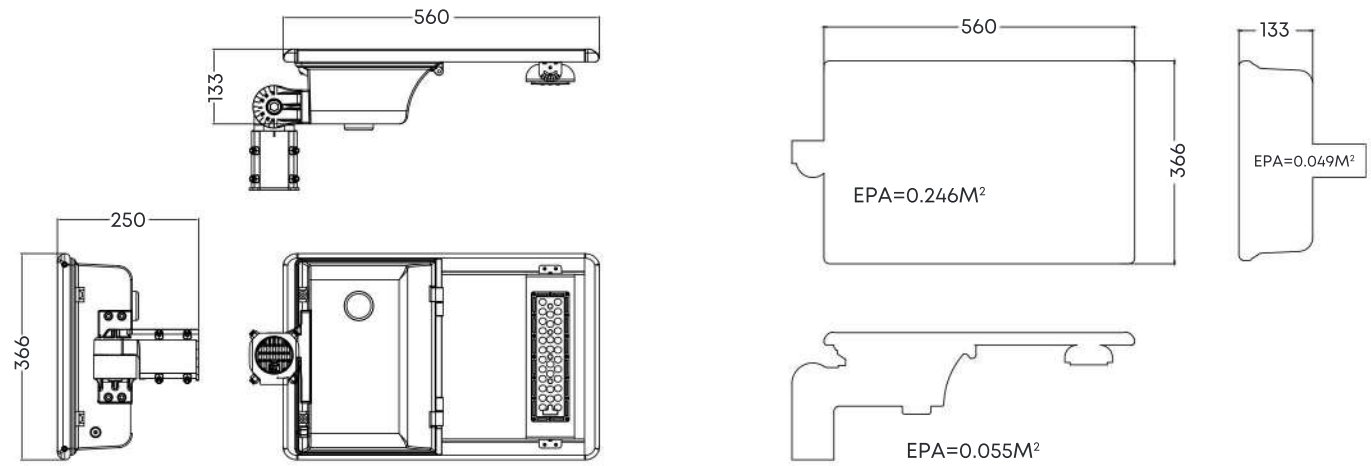
10W-15W



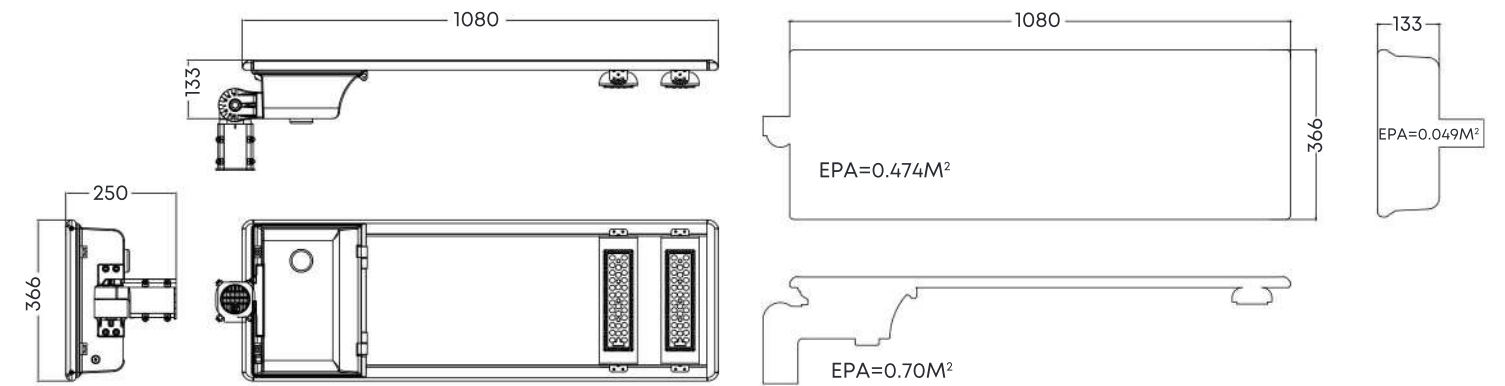
50W



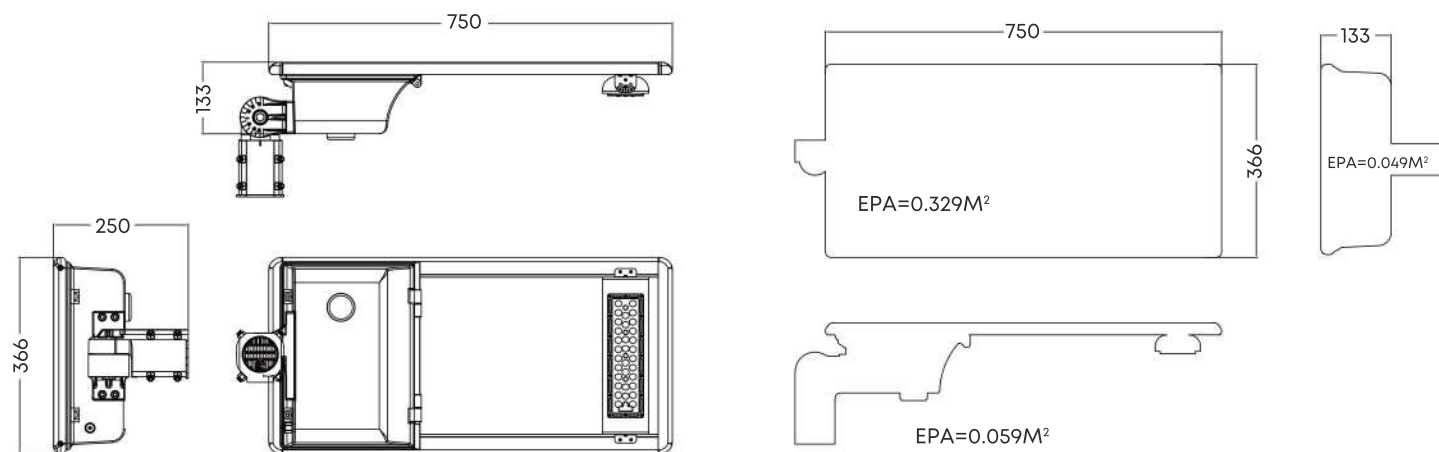
27W



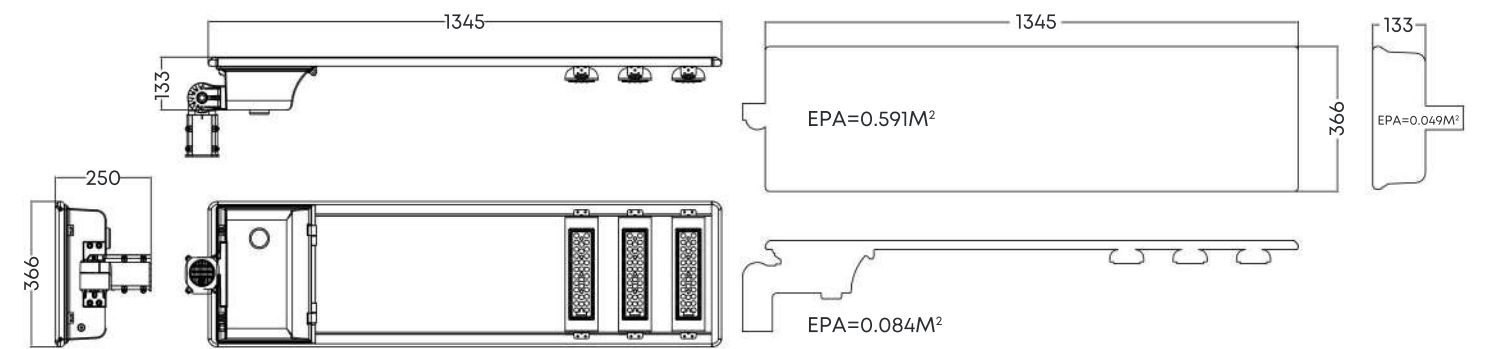
67W



40W



95W



SES Series Specification Sheet

*Due to the constant improvements in product development, individual parameters might change. Please refer to our sales or R&D team for most up-to-date content as specifications are subject to change without notice.

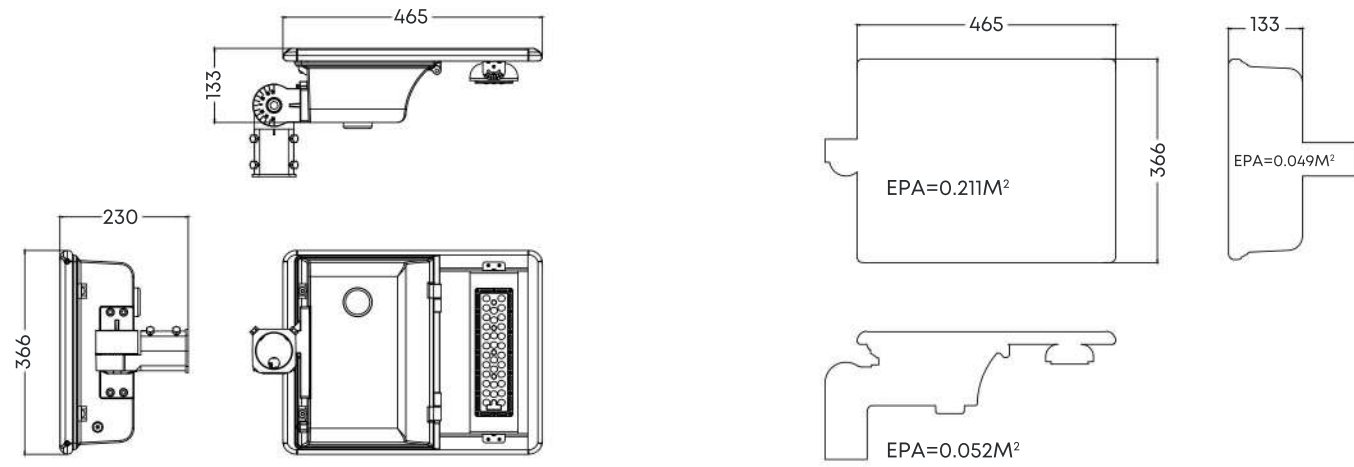
Tel: (+34) 93 3174 008
E-mail: info@carandini.com
Web: carandini.com

Adress: C Y G Carandini, S.A.U. Anselm Clavé, 22408186 Lliçà d'Amunt Barcelona, Spain

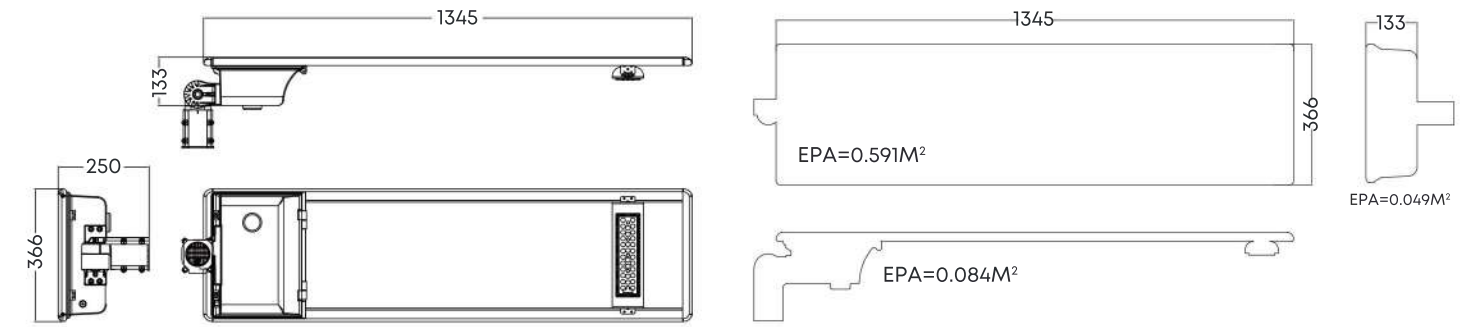


Dimensions (Length unit: mm) *Autonomy 12-16 Hours without dimming profile without run time extension

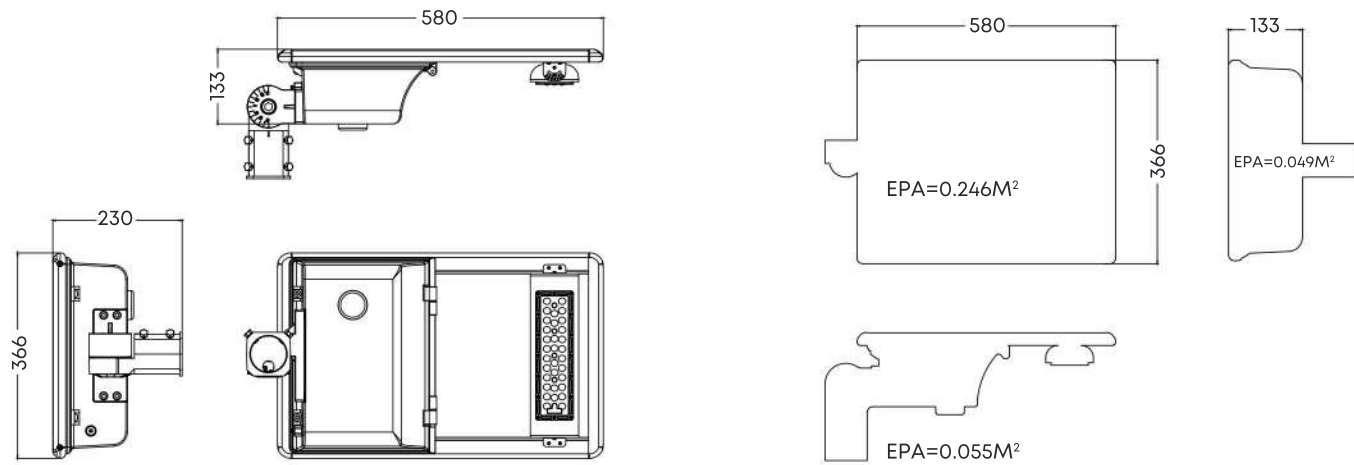
10W



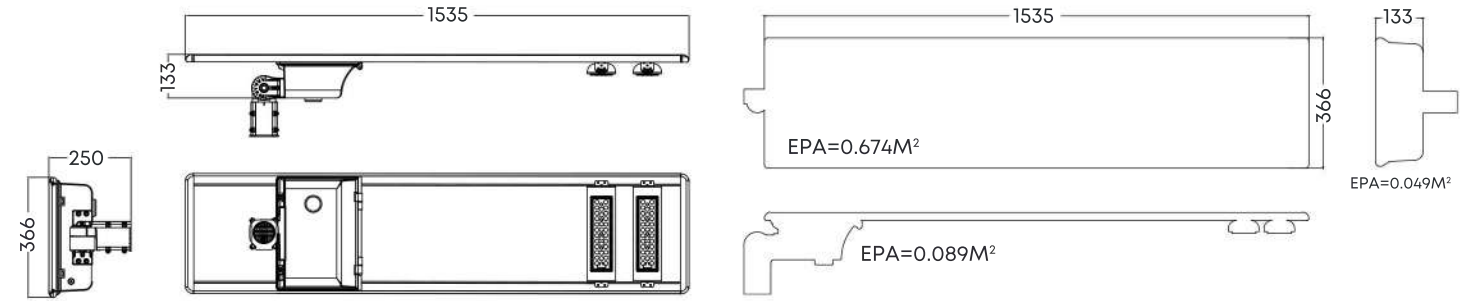
40W



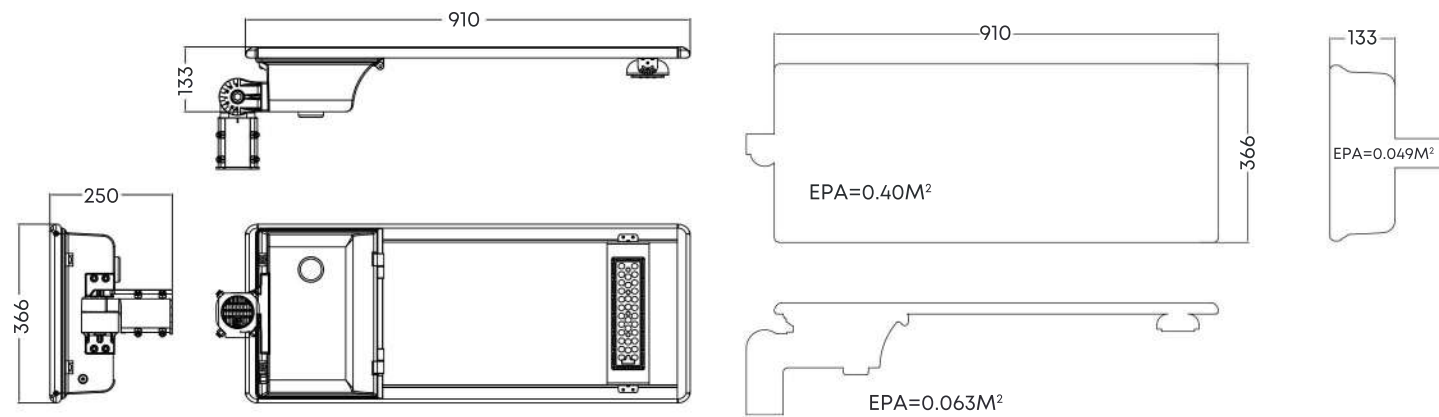
15W



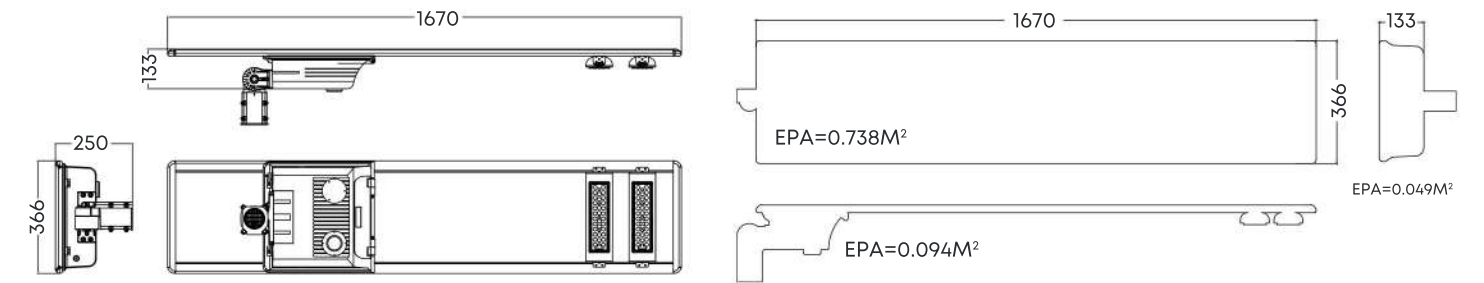
50W



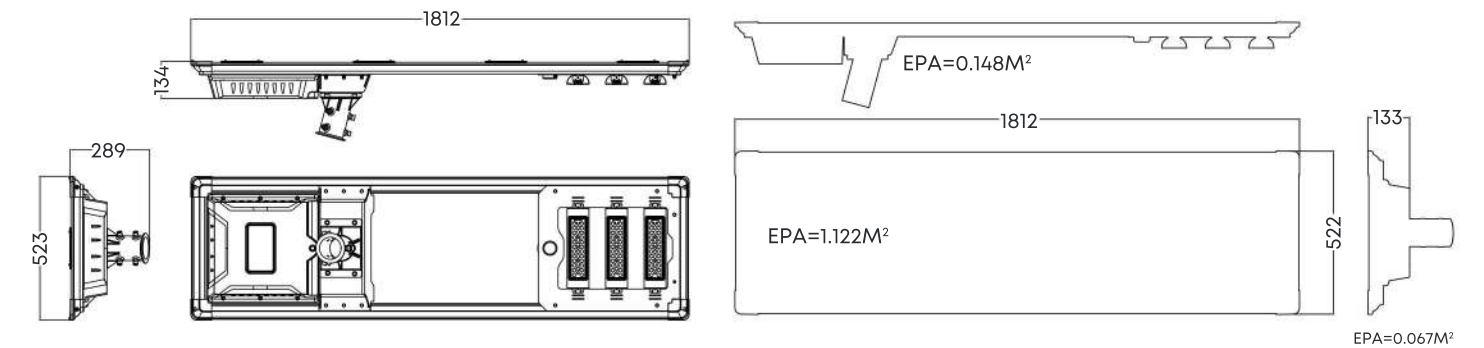
27W



67W



95W



SES Series Specification Sheet

*Due to the constant improvements in product development, individual parameters might change. Please refer to our sales or R&D team for most up-to-date content as specifications are subject to change without notice.

Tel: (+34) 93 3174 008
E-mail: info@carandini.com
Web: carandini.com

Address: C Y G Carandini, S.A.U. Anselm Clavé, 22408186 Lliçà d'Amunt Barcelona, Spain





Tel: (+34) 93 3174 008

E-mail: info@carandini.com

Web: carandini.com

Adress: C Y G Carandini, S.A.U. Anselm Clavé,
22408186 Lliçà d'Amunt Barcelona, Spain